

Operator's Manual



optris[®] CX

Infrared thermometer

Optris GmbH

Ferdinand-Buisson-Str. 14

D – 13127 Berlin

Germany

Tel.: +49 30 500 197-0

Fax: +49 30 500 197-10

E-mail: info@optris.de

Internet: www.optris.de



Table of contents

1	General notes	7
1.1	Intended use	7
1.2	Warranty	8
1.3	Scope of delivery	9
1.4	Maintenance	9
1.4.1	Cleaning	9
2	Technical Data	11
2.1	Default settings	11
2.2	General specifications	12
2.3	Electrical specifications	13
2.4	Measurement specifications	14
2.5	Optical charts	16

2.6	CF-optics and protective window.....	17
3	Installation.....	19
3.1	Mechanical Installation	19
3.2	Electrical Installation	23
4	Software CompactConnect.....	29
4.1	Installation.....	29
5	Digital command set.....	33
6	Basics of Infrared Thermometry	35
7	Emissivity	37
7.1	Definition.....	37
7.2	Determination of unknown emissivity	37
7.3	Characteristic emissivity	39
Appendix A – Table of emissivity for metals		41
Appendix B - Table of emissivity for non-metals		43

Appendix C – Direct connection to a RS232 interface..... 45

Appendix D - Smart Averaging..... 47

Appendix E – CE conformity 49

1 General notes

1.1 Intended use

The sensors of the optris CX series are non-contact infrared temperature sensors. They calculate the surface temperature based on the emitted infrared energy of objects [**► 7 Basics of Infrared Thermometry**].



The CX sensors are sensitive optical systems. Use the thread for mechanical installation only.



- Avoid abrupt changes of the ambient temperature.
- Avoid mechanical violence on the head – this may destroy the system (expiry of warranty).
- In case of problems or questions which may arise when you use the infrared camera contact our service department.



Read the manual carefully before the initial start-up. The producer reserves the right to change the herein described specifications in case of technical advance of the product.



► All accessories can be ordered according to the referred part numbers in brackets [].

1.2 Warranty

Each single product passes through a quality process. Nevertheless, if failures occur contact the customer service at once. The warranty period covers 24 months starting on the delivery date. After the warranty is expired the manufacturer guarantees additional 6 months warranty for all repaired or substituted product components. Warranty does not apply to damages, which result from misuse or neglect. The warranty also expires if you open the product. The manufacturer is not liable for consequential damage or in case of a non-intended use of the product.

If a failure occurs during the warranty period the product will be replaced, calibrated or repaired without further charges. The freight costs will be paid by the sender. The manufacturer reserves the right to exchange components of the product instead of repairing it. If the failure results from misuse or neglect the user has to pay for the repair. In that case you may ask for a cost estimate beforehand.

1.3 Scope of delivery

- CX incl. connection cable, mounting nut and user's manual

1.4 Maintenance



Never use cleaning compounds which contain solvents (neither for the lens nor for the housing).

1.4.1 Cleaning

Blow off loose particles using clean compressed air. The lens surface can be cleaned with a soft, humid tissue moistened with water or a water based glass cleaner.

2 Technical Data

2.1 Default settings



Smart Averaging means a dynamic average adaptation at high signal edges. [Activation via software only]. [► **Appendix D**]



If the unit is supplied together with the USB kit the output is already pre-set to digital communication (bidirectional).

At time of delivery the unit has the following pre-settings:

Temperature range:	-18...500 °C/ according 4...20 mA
Emissivity:	0.950
Transmission:	1.000
Smart averaging:	active
Ambient temperature source:	Head temperature

2.2 General specifications

Environmental rating:	IP65 (NEMA-4)
Ambient temperature:	-20...75 °C
Storage temperature:	-40...85 °C
Relative humidity :	10...95 %, non-condensing
Material:	aluminum, black anodized
Dimensions:	Diameter: 42 mm/ Length: 130 mm

Weight:	350 g
Cable length:	5 m
Cable diameter:	4.3 mm
Vibration:	IEC 60068-2-6 (sinus shaped), IEC 60068-2-64 (Broad band noise)
Shock:	IEC 60068-2-27 (25 g and 50 g)

2.3 Electrical specifications

Output/ analog:	4-20 mA/ scalable
Output/ serial digital: ¹⁾	uni- (burst mode) or bi-directional
Alarm output:	programmable open collector output/ 0...30 VDC; 500 mA
Output impedances:	max 1000 Ω loop impedance
Power supply:	5...28 VDC

¹⁾ *Inverted RS232 signal, TTL, 9.6 kBaud*

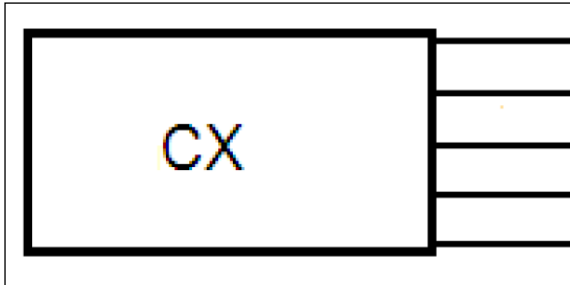

white	Current loop (+)
yellow	TxD (5 V)
green	RxD (5 V)/ Open-collector output
brown	Current loop (-)/ Ground (⊥)
black	Shield

Figure 1: Dimensions CX

2.4 Measurement specifications

Temperature range IR:	-30...900 °C (scalable via software)
Spectral range:	8...14 μm
Optical resolution:	22:1
CF-lens (optional):	0.6 mm@ 10 mm
Accuracy: ¹⁾	±1.5 °C or ±1,5 %
Repeatability: ¹⁾	±0.75 °C or ±0.75 %

Temperature resolution:	0.2 °C
Response time:	150 ms (95 % signal)
Warm-up time:	10 min
Emissivity/ Gain:	0.100...1.100 (adjustable via software)
Transmissivity:	0.100...1.000 (adjustable via software)
Interface (optional):	USB programming interface
Signal processing:	Average, peak hold, valley hold (adjustable via software)
Software (optional):	CompactConnect

¹⁾ at ambient temperature of 23 ± 5 °C; whichever is greater

2.5 Optical charts



- The size of the measuring object and the optical resolution of the infrared thermometer determine the maximum distance between sensing head and measuring object.
- In order to prevent measuring errors the object should fill out the field of view of the optics completely. Consequently, the spot should at all times have at least the same size like the object or should be smaller than that.

The following optical charts show the diameter of the measuring spot in dependence on the distance between measuring object and sensing head. The spot size refers to **90 % of the radiation energy**. The distance is always measured from the front edge of the sensor housing/ CF-lens holder/ air purge.

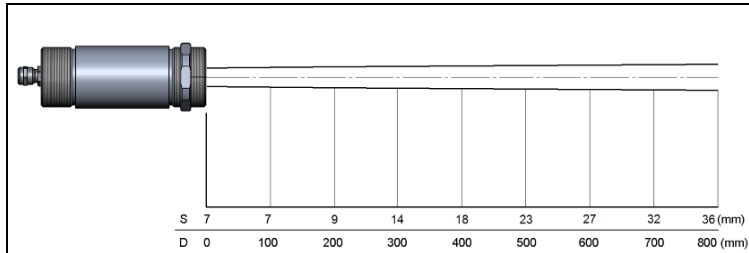

Figure 2: Optical chart optris CX (22:1)

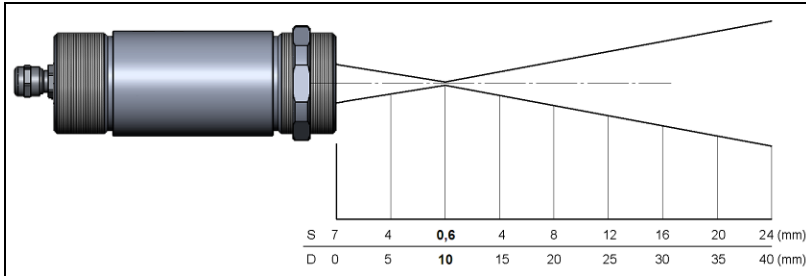

Figure 3: Optical chart optris CX with CF-lens (0.6 mm@ 10 mm)

2.6 CF-optics and protective window



- If the CF-lens is used, the transmission has to be set to **0.78**. To change this value the optional USB-Kit (including software) is necessary.
- The assigned transmission (average value) is a characteristic value which may have a certain scattering. If required the transmission has to be determined.

The optional CF-lens allows the measurement of small objects. For protection of the sensing head optics a protective window is available. The mechanical dimensions are equal to the CF lens.

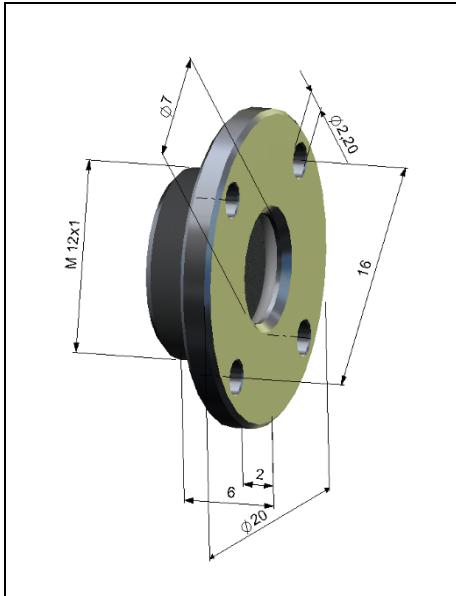

Figure 4: CF-lens [Order No.: ACCXCF]/ protective window [Order No.: ACCXPW]

3 Installation

3.1 Mechanical Installation

The CX is equipped with a 20 UNF-2B thread and can be installed either directly via the sensor thread or with the help of the hex nut (standard) to the mounting bracket available.

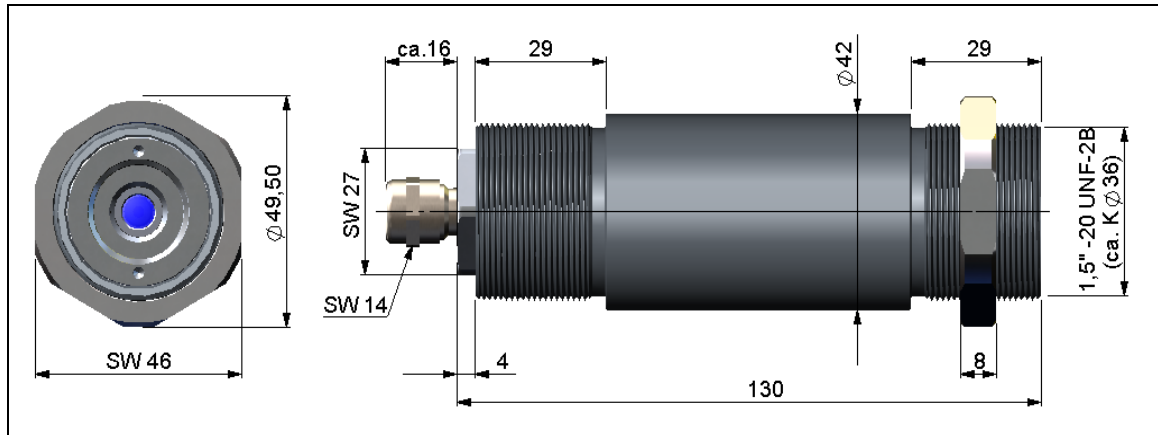

Figure 5: CX - Dimensions

Mounting bracket

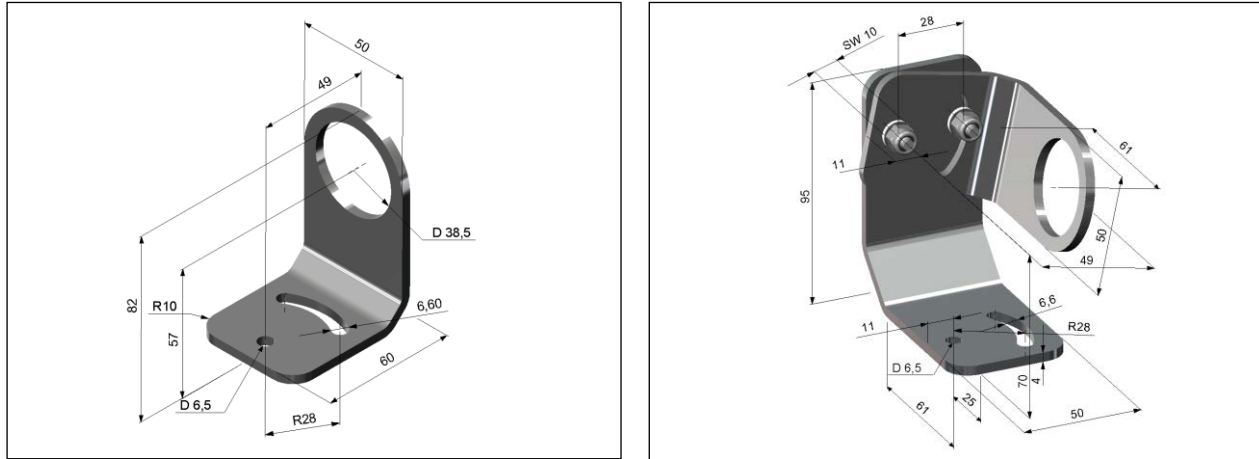

Figure 6: Mounting angle [Order No.: ACCXFB] and adjustment angle [Order No.: ACCXAB] for CX

Air purge collar



- Use oil-free, technically clean air only.
- The needed amount of air (approx. 2...10 l/ min.) depends on the application and the installation conditions on-site.

The lens must be kept clean at all times from dust, smoke, fumes and other contaminants in order to avoid reading errors. These effects can be reduced by using an **air purge collar**.

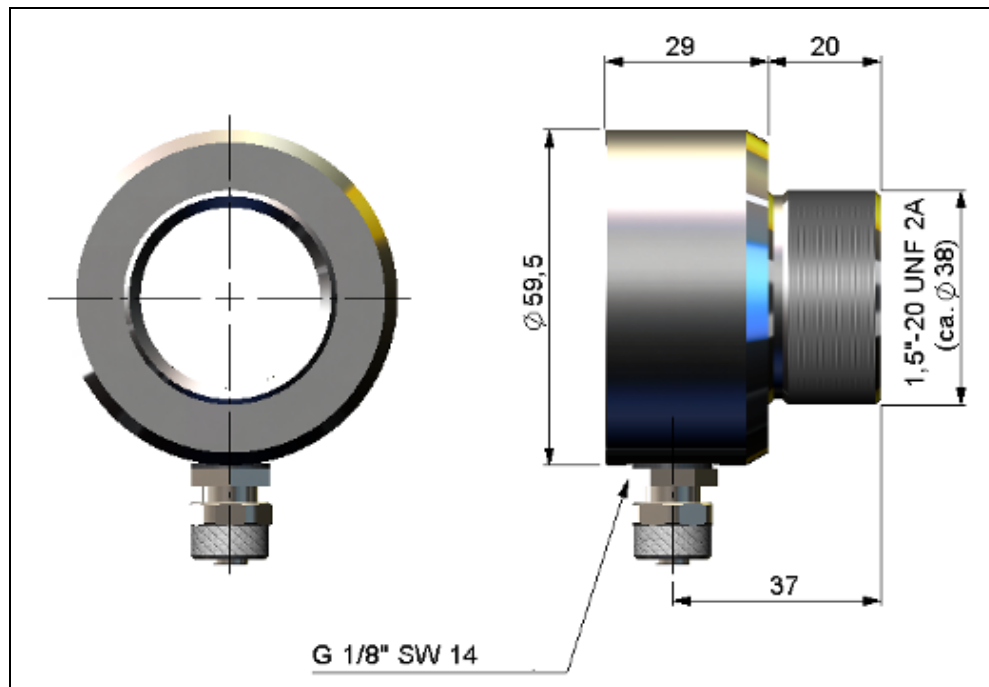

Figure 7: Air purge collar [Order No.: ACCXAP]; Hose connection: 6x8 mm

3.2 Electrical Installation

Analog device (mA-output)



- Use shielded cables only. The sensor shield has to be grounded.
- Use a separate, stabilized power supply unit with an output voltage in the range of **5–28 VDC** which can supply **100 mA**. The residual ripple should be max **200 mV**.
- The maximum loop impedance is 1000 Ω .

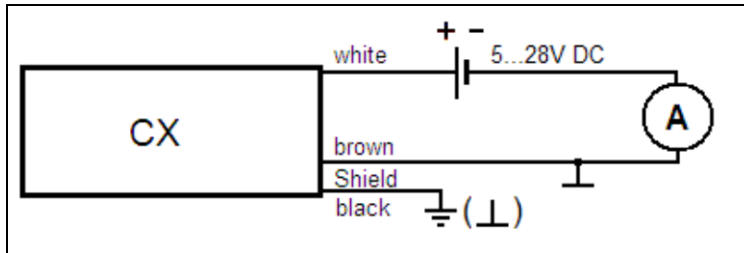

Figure 8: Wiring diagram of the analog device

Digital Communication

For digital communication the optional USB programming kit is required.



Figure 9: USB-Kit: USB programming adaptor incl. terminal block and software CD [Order No.: **ACCSUSBK**]

Connecting of the sensor cable and the USB cable

1. Connect each wire of the USB adapter cable with the same colored wire of the sensor cable by using the terminal block.
2. To switch off a contact press the screw driver into the block as shown in **Figure 10**.

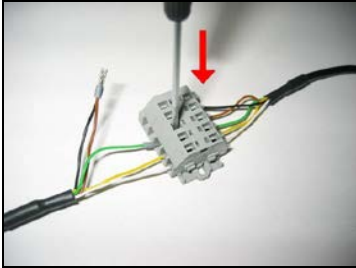

Figure 10: Connecting of the sensor cable and USB cable

The sensor is offering two ways of digital communication:

- bidirectional communication (sending and receiving data)
- unidirectional communication (burst mode – the sensor is sending data only)

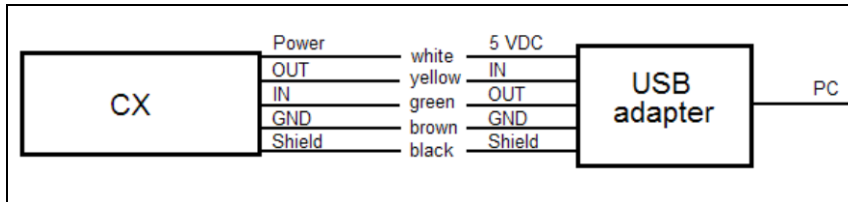

Figure 11: Device with digital pin

Analog + Digital

The optris CX is able to work in the digital mode and simultaneously as analog device (4-20 mA). In this case the sensor will be powered by the USB interface (5 V).

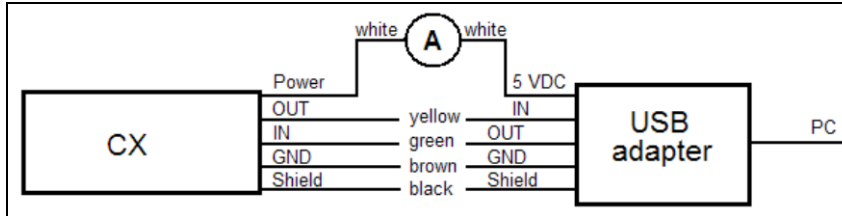

Figure 12: Simultaneous analog and digital application

Analog + Alarm

The alarm output (open collector output) can control an external relay. In addition the analog output can be used simultaneously.

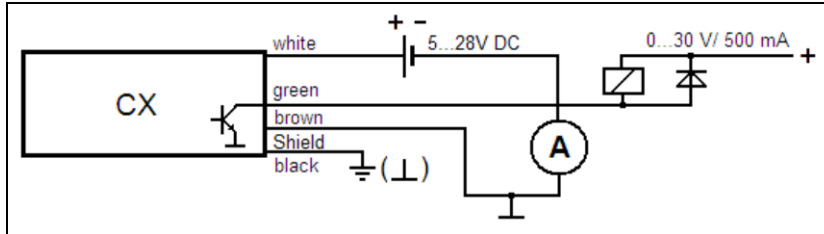

Figure 13: Analog device with alarm output

4 Software CompactConnect



Minimum system requirements:

- Windows Vista, Windows 7, Windows 8
- USB interface
- Hard disc with at least 30 MByte of free space
- At least 128 MByte RAM
- CD-ROM drive



A detailed description is provided in the software manual on the software CD.

4.1 Installation

1. Insert the installation CD into the according drive on your computer. If the **autorun option** is activated the installation wizard will start automatically.
2. Otherwise start **CDsetup.exe** from the CD-ROM. Follow the instructions of the wizard until the installation is finished.

The installation wizard will place a launch icon on the desktop and in the start menu:
Start\Programs\CompactConnect

To uninstall the software from your system use the **uninstall** icon in the start menu.

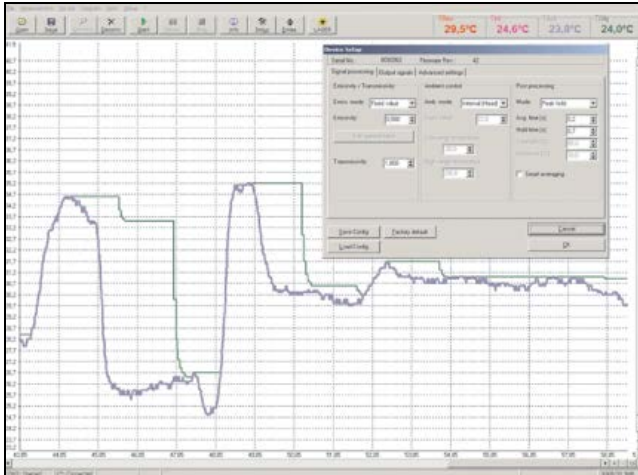

Figure 14: Software CompactConnect

Main functions:

- Graphic display for temperature trends and automatic data logging for analysis and documentation
- Complete sensor setup and remote controlling
- Adjustment of signal processing functions
- Programming of outputs and functional inputs

5 Digital command set

Kommandoliste CS/ CSmicro/ CX							
DEZIMAL	HEX	Binär / ASCII	Kommando	Daten	Antwort	Ergebnis	Einheit
1	0x01	Binär	LESEN Temp - Target	keine	byte1 byte2	= (byte1 x 256 + byte2 - 1000) / 10	°C
2	0x02	Binär	LESEN Temp - Head	keine	byte1 byte2	= (byte1 x 256 + byte2 - 1000) / 10	°C
3	0x03	Binär	LESEN aktuelle Temp - Target	keine	byte1 byte2	= (byte1 x 256 + byte2 - 1000) / 10	°C
4	0x04	Binär	LESEN Emissionsgrad	keine	byte1 byte2	= (byte1 x 256 + byte2) / 1000	
5	0x05	Binär	LESEN Transmission	keine	byte1 byte2	= (byte1 x 256 + byte2) / 1000	
9	0x09	Binär	LESEN Prozessor Temperatur	keine	byte1	= (byte1 x 256 + byte2 - 1000) / 10	
14	0x0E	Binär	LESEN Serien Nummer	keine	byte1 byte2 byte3	= byte1 x 65536 + byte2 x 256 + byte3	
15	0x0F	Binär	LESEN FW Rev.	keine	byte1 byte2	= byte1 x 256 + byte2	
129	0x81	Binär	SETZEN DAC mV/ mA	byte1	byte1	byte 1= mV (mA) x 10 (z.B. 4mA = 4 x 10=40)	°C
130	0x82	Binär	RÜCKSETZEN der DAC mV/ mA Ausgabe				
132	0x84	Binär	SETZEN Emissionsgrad	byte1 byte2	byte1 byte2	= (byte1 x 256 + byte2) / 1000	

Temperaturberechnung bei CSmicro hs: (byte1 x 256 + byte2 - 10000) / 100

BEISPIELE (alle Bytes in HEX)

Lesen der Objekttemperatur

Senden: 01 Kommando zum Lesen der Objekt Temperatur
 Empfangen: 04 D3 Objekttemperatur in Zehntel Grad + 1000 04 D3 = dez. 1235
 1235 - 1000 = 235
 235 / 10 = **23,5 °C**

Lesen der Objekttemperatur (bei CSmicro 2Whs)

Senden: 01 Kommando zum Lesen der Objekt Temperatur
 Empfangen: 30 3E Objekttemperatur in Hunderstel Grad + 10000 30 3E = dez. 12350
 12350 - 10000 = 2350
 2350 / 100 = **23.50 °C**

Setzen des Emissionsgrades

Senden: 84 03 B6 03B6 = dez. 950
 Empfangen: 03 B6 950 / 1000 = **0,950**

Burstmode (unidirektional)			
Nach Aktivierung wird ein kontinuierliches Signal erzeugt. Der Burst-String kann mit Hilfe der Software konfiguriert werden.			
Burst string	Beispiel	kompletter Burst-String	Umsetzung in Dezimalwert
2 Synchronisations-Bytes: AAAA	-----		-----
2 Bytes für jeden Ausgangswert (HI LO)	03B8	AAAA 03B8	Prozesstemp. [°C] = (Hex => Dec(03B8)-1000)/10 = -4,8

Figure 15: Digital command set

6 Basics of Infrared Thermometry

Depending on the temperature each object emits a certain amount of infrared radiation. A change in the temperature of the object is accompanied by a change in the intensity of the radiation. For the measurement of “thermal radiation” infrared thermometry uses a wave-length ranging between 1 μ and 20 μ m. The intensity of the emitted radiation depends on the material. This material contingent constant is described with the help of the emissivity which is a known value for most materials (see enclosed table emissivity).

Infrared thermometers are optoelectronic sensors. They calculate the surface temperature on the basis of the emitted infrared radiation from an object. The most important feature of infrared thermometers is that they enable the user to measure objects contactless. Consequently, these products help to measure the temperature of inaccessible or moving objects without difficulties. Infrared thermometers basically consist of the following components:

- lens
- spectral filter
- detector
- electronics (amplifier/ linearization/ signal processing)

The specifications of the lens decisively determine the optical path of the infrared thermometer, which is characterized by the ratio Distance to Spot size.

The spectral filter selects the wavelength range, which is relevant for the temperature measurement. The detector in cooperation with the processing electronics transforms the emitted infrared radiation into electrical signals.

7 Emissivity

7.1 Definition

The intensity of infrared radiation, which is emitted by each body, depends on the temperature as well as on the radiation features of the surface material of the measuring object. The emissivity (ϵ – Epsilon) is used as a material constant factor to describe the ability of the body to emit infrared energy. It can range between 0 and 100 %. A “blackbody” is the ideal radiation source with an emissivity of 1.0 whereas a mirror shows an emissivity of 0.1.

If the emissivity chosen is too high, the infrared thermometer may display a temperature value which is much lower than the real temperature – assuming the measuring object is warmer than its surroundings. A low emissivity (reflective surfaces) carries the risk of inaccurate measuring results by interfering infrared radiation emitted by background objects (flames, heating systems, chamottes). To minimize measuring errors in such cases, the handling should be performed very carefully and the unit should be protected against reflecting radiation sources.

7.2 Determination of unknown emissivity

- ▶ First determine the actual temperature of the measuring object with a thermocouple or contact sensor. Second, measure the temperature with the infrared thermometer and modify the emissivity until the displayed result corresponds to the actual temperature.

- If you monitor temperatures of up to 380°C you may place a special plastic sticker (emissivity dots – **Order No.: ACLSED**) onto the measuring object, which covers it completely.
1. Set the emissivity to 0.95 and take the temperature of the sticker.
 2. Afterwards, determine the temperature of the adjacent area on the measuring object and adjust the emissivity according to the value of the temperature of the sticker.
 3. Cover a part of the surface of the measuring object with a black, flat paint with an emissivity of 0.98. Adjust the emissivity of your infrared thermometer to 0.98 and take the temperature of the colored surface.
 4. Afterwards, determine the temperature of a directly adjacent area and modify the emissivity until the measured value corresponds to the temperature of the colored surface.

CAUTION: On all three methods the object temperature must be different from ambient temperature.

7.3 Characteristic emissivity

In case none of the methods mentioned above help to determine the emissivity you may use the emissivity table ► **Appendix A** and **Appendix B**. These are average values, only. The actual emissivity of a material depends on the following factors:

- temperature
- measuring angle
- geometry of the surface
- thickness of the material
- constitution of the surface (polished, oxidized, rough, sandblast)
- spectral range of the measurement
- transmissivity (e.g. with thin films)

Appendix A – Table of emissivity for metals

Material		typical Emissivity
Aluminium	non oxidized	0,02-0,1
	polished	0,02-0,1
	roughened	0,1-0,3
	oxidized	0,2-0,4
Brass	polished	0,01-0,05
	roughened	0,3
	oxidized	0,5
Copper	polished	0,03
	roughened	0,05-0,1
	oxidized	0,4-0,8
Chrome		0,02-0,2
Gold		0,01-0,1
Haynes	alloy	0,3-0,8
Inconel	electro polished	0,15
	sandblast	0,3-0,6
	oxidized	0,7-0,95
Iron	non oxidized	0,05-0,2
	rusted	0,5-0,7
	oxidized	0,5-0,9
	forged, blunt	0,9
Iron, casted	non oxidized	0,2
	oxidized	0,6-0,95
Lead	polished	0,05-0,1

Material		typical Emissivity
Lead	roughened	0,4
	oxidized	0,2-0,6
Magnesium		0,02-0,1
Mercury		0,05-0,15
Molybdenum	non oxidized	0,1
	oxidized	0,2-0,6
Monel (Ni-Cu)		0,1-0,14
Nickel	electrolytic	0,05-0,15
	oxidized	0,2-0,5
Platinum	black	0,9
Silver		0,02
Steel	polished plate	0,1
	rustless	0,1-0,8
	heavy plate	0,4-0,6
	cold-rolled	0,7-0,9
	oxidized	0,7-0,9
Tin	non oxidized	0,05
Titanium	polished	0,05-0,2
	oxidized	0,5-0,6
Wolfram	polished	0,03-0,1
Zinc	polished	0,02
	oxidized	0,1

Appendix B - Table of emissivity for non-metals

Material		typical Emissivity			
		1,0 μm	2,2 μm	5,1 μm	8-14 μm
Spectral response					
Asbestos		0,9	0,8	0,9	0,95
Asphalt				0,95	0,95
Basalt				0,7	0,7
Carbon	non oxidized		0,8-0,9	0,8-0,9	0,8-0,9
	graphite		0,8-0,9	0,7-0,9	0,7-0,8
Carborundum			0,95	0,9	0,9
Ceramic		0,4	0,8-0,95	0,8-0,95	0,95
Concrete		0,65	0,9	0,9	0,95
Glass	plate		0,2	0,98	0,85
	melt		0,4-0,9	0,9	
Grit				0,95	0,95
Gypsum				0,4-0,97	0,8-0,95
Ice					0,98
Limestone				0,4-0,98	0,98
Paint non alkaline					0,9-0,95
Paper any color				0,95	0,95
Plastic >50 μm non transparent				0,95	0,95
Rubber				0,9	0,95
Sand				0,9	0,9
Snow					0,9
Soil					0,9-0,98
Textiles				0,95	0,95
Water					0,93
Wood natural				0,9-0,95	0,9-0,95

Appendix C – Direct connection to a RS232 interface

For a bidirectional RS232 connection of the sensor we recommend the interface circuit from Maxim, e.g. **MAX3381E**.

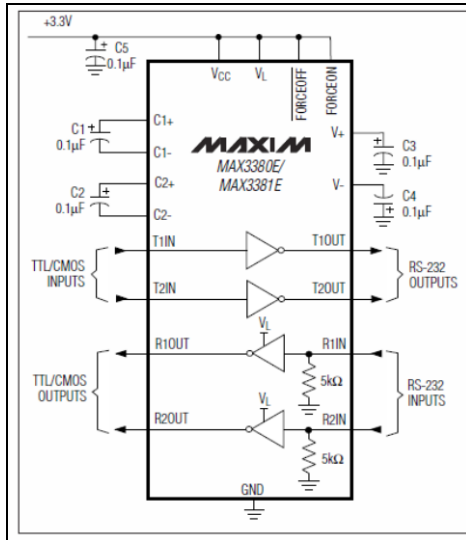

Model	CX
UART-Voltage (RxD)	3,3 V
UART-Voltage (TxD)	2,5 V
CX connections:	TxD (yellow) an T1IN RxD (green) an R1OUT GND (brown) an GND
PC connections:	connect T1OUT with RxD (PC) connect R1IN with TxD (PC)

Appendix D - Smart Averaging

The average function is generally used to smoothen the output signal. With the adjustable parameter time this function can be optimal adjusted to the respective application. One disadvantage of the average function is that fast temperature peaks which are caused by dynamic events are subjected to the same averaging time. Therefore those peaks can only be seen with a delay on the signal output.

The function **Smart Averaging** eliminates this disadvantage by passing those fast events without averaging directly through to the signal output.

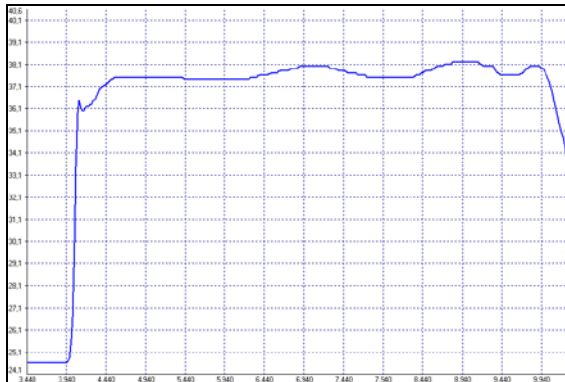

Signal graph with Smart Averaging function

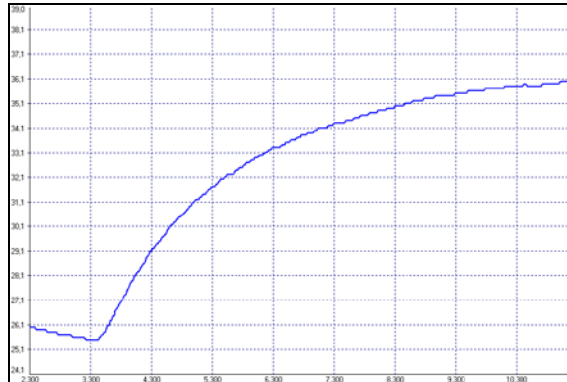

Signal graph without Smart Averaging function

Appendix E – CE conformity

EG-Konformitätserklärung EU Declaration of Conformity



Wir / We

Optris GmbH
Ferdinand Buisson Str. 14
D-13127 Berlin

erklären in alleiniger Verantwortung, dass
declare on our own responsibility that

die Produktserie optris CX/ CX hs
the product group optris CX/ CX hs

den Anforderungen der EMV-Richtlinie 2004/108/EG und der Niederspannungsrichtlinie
2006/95/EG entspricht.
meets the provisions of the EMC Directive 2004/108/EG and the Low Voltage Directive
2006/95/EG.

Angewandte harmonisierte Normen:
Applied harmonized standards:

EMV Anforderungen / EMC General Requirements:

EN 61326-1:2006 (Grundlegende Prüfanforderungen / Basic requirements)
EN 61326-2-3:2006

Gerätesicherheit von Messgeräten / Safety of measurement devices:

EN 61010-1:2010
EN 60825-1:2007 (Lasersicherheit / Laser safety)

Dieses Produkt erfüllt die Vorschriften der Richtlinie 2011/65/EU des Europäischen Parlaments und
des Rates vom 8. Juni 2011 zur Beschränkung der Verwendung bestimmter gefährlicher Stoffe in
Elektro- und Elektronikgeräten.
This product is in conformity with Directive 2011/65/EU of the European Parliament and of the
Council of 8 June 2011 on the restriction of the use of certain hazardous substances in electrical
and electronic equipment.

Berlin, 18.09.2014

Ort, Datum / place, date

Dr. Ulrich Klientz
Geschäftsführer / General Manager

optris CX-MA-E2014-12-B